

## Installation Manual

### Surge Protective Devices for LED drivers & Luminaires

Surge Protective Device (SPD) protects electrical system and equipment against various over voltages and impulse currents such as lighting and switching surges. SPD limits the surge voltage value and discharges the currents associated with surge voltages. Surge currents can flow to the supply network or to the ground. When having electronic components within lighting systems, it is necessary to protect them against power supply interruptions and electric overloads – power surges.

### Safety

Risk of electric shock. Please read carefully instruction before attempting installation. The installation and startup of this device may only be performed by an authorized (electrically) skilled person. The relevant country specific regulations must be observed. Only for safety class I and safety class II mains powered electronic devices. Check for damage prior to install. If the product is damaged don't use it. Do not use if the supply voltage is out of the range. All connections and disconnections must be carried out at absence of the mains supply voltage. No user serviceable parts inside. The defective device must be replaced by the new one. Any alteration or modification of this product is expressly forbidden as it may cause property damage other equipment or the product malfunction.

### Usage

The SPD protects only the LED control gears and LED luminaires. Only usage as "built-in" is allowed. The SPD must be fastened inside in the case with appropriate ingress protection rating - LED luminaire, street pillar metal shield, etc. Do not expose the SPD body or wires to the direct sunlight. Do not exceed the declared temperatures. Do not exceed the rated values of mains supply voltage and load currents. When LED status indicator stops light the protector must be replaced by the new one. When outside backup fuse is interrupted must be replaced by the new one. The input of T3 and combined T2&T3 protector will be switch off from mains supply when status LED is not lights on. At "the end of life" the LED indicator stops light on and the SPD must be replaced by the new one.

### Connections

There are the two groups of SPDs by connections - by wires and by terminal blocks.

The all models with built-in terminal block must be connect to the protected driver and to mains supply network via external wires with suitable cross-section. Thus, they can be installed in smaller volumes of space than other protectors with wires. They have own LED status "end of life" indicator and thermal link.

The SPD input wires must be connected to the mains supply conductors in parallel to the placed ones. The SPD output wires must be connected close as possible to input terminals of protected LED driver/power supply at T3 type connections and at T2&T3 models. When protector is connected as T2 type of work the SPD T2 and T2&T3 combined type the "protected" can be local mains supply network and devices. Do not exceed the total output current (rms) of SPD. Do not change polarity of wires and terminals when make connections. The all connections of SPD's wires must be made properly by usage of the appropriate terminals. The all input wires of SPD – Line in, Neutral in, PE/GND must be connected and placed in such a way that they will have the smallest possible length and without any bends or loops. The earthing of the protected luminaire or local protected mains network in the TT system must be in order. Take attention where the SPD PE/GND wire connects to the local earthing point at TT system. At TT grid system must be cut the tinned end of yellow-green PE/GND wire of SPD, strip the insulation and press the cable shoe with properly sizes according to the local earthing point. Take attention when SPD PE/GND wire connects to the PE conductor. Please see the marking of the body of SPD model and the application diagram.

### T2&T3 SPD connection

When multi-level protection concept is used a T3 type SPD and an upstream T2 type SPD are to be coordinated.

The protected voltage level "Up" of T3 SPD must be greater or equivalent of the "Up" of type 2 SPD. Please take attention of the immunity properties of intended to surge protection device.

### Models Available

SPD model	Supply voltage 50/60Hz	Uc max	Up(L-N)	Up(L/N-PE)	In, 8/20uS		Imax, 8/20uS		Uoc, 1.2/50u S	Load current	Length	Width	Height	Fixing
	VAC	VAC	kV	kV	kA	Strikes min	kA	Strikes min	kV	A	(mm)	(mm)	(mm)	
Models with Cables for Safety Class I devices														
LED SPD 20kA T2	100 ... 264	275	1.5	1.8	10	20	20	1	x	x	85	43	35	M8x10
LED SPD 10kA T2	100 ... 264	275	1.5	1.8	5	20	10	1	x	x	68	34	30	M8x10
LED SPD T2&T3 10kVW	100 ... 277	280	1.8	2.0	5	20	10	1	10	5	68	34	30	M8x10
Models with Terminal blocks for Safety Class I devices														
LED SPD T2&T3 10kVT	100 ... 277	280	1.8	2.0	5	20	10	1	10	5	77	34	30	M8x10
LED SPD 10kVL T3	100 ... 277	280	1.8	2.0	5	20	10	1	10	5	77	34	30	M8x10
LED SPD T2&T3 10kVT3	100 ... 277	280	1.8	2.0	5	20	10	1	10	5	77	34	30	M8x10
Models with Terminal blocks for Safety Class II devices														
LED SPD 10kVIL T3	100 ... 277	280	1.8	x	5	20	10	1	10	5	77	34	30	M8x10
LED SPD T2&T3 10kVIIT	100 ... 277	280	1.8	x	5	20	10	1	10	5	77	34	30	M8x10

**Application diagrams**

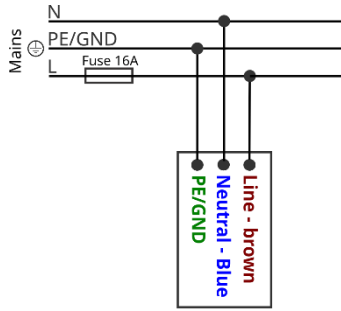

LED SPD 10kA&20kA T2  
T2 type connections  
when "end of life" is reached  
the protector is no more  
protects the line

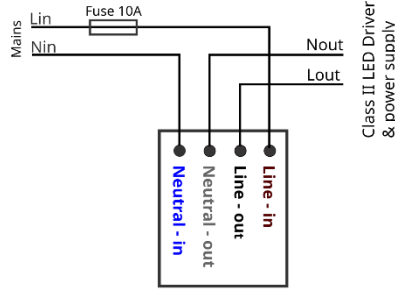

LED SPD 10kVIII T3  
T3 type connections  
when "end of life" is reached  
the protector and load are  
switched off from mains

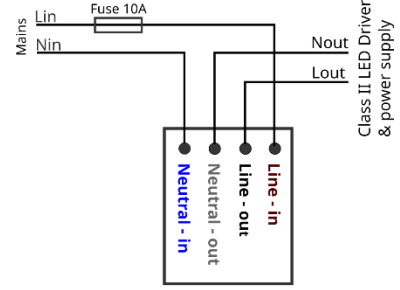

LED SPD T2&T3 10kVIII  
T3 type connections  
when "end of life" is reached  
the protector and load are  
switched off from mains

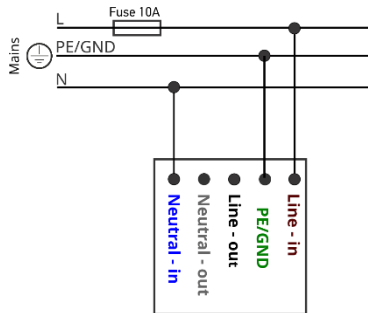

LED SPD T2&T3 10kVW  
T2 type connections  
when "end of life" is reached  
the protector is no more  
protects the line

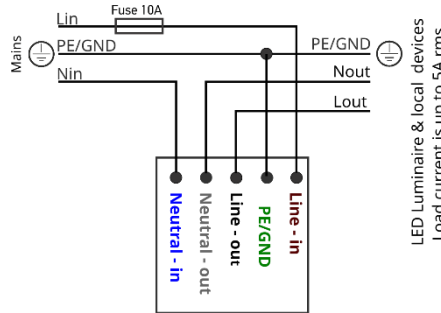

LED SPD T2&T3 10kVW  
T2 type connections  
when "end of life" is reached  
the protector and load are  
switched off from mains

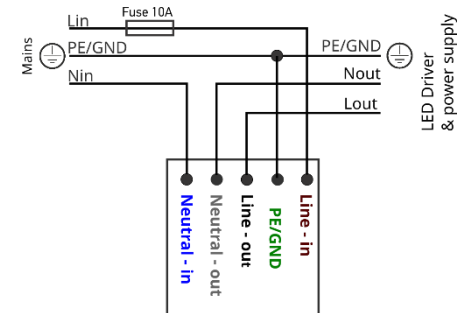

LED SPD T2&T3 10kVW  
T3 type connections  
when "end of life" is reached  
the protector and load are  
switched off from mains

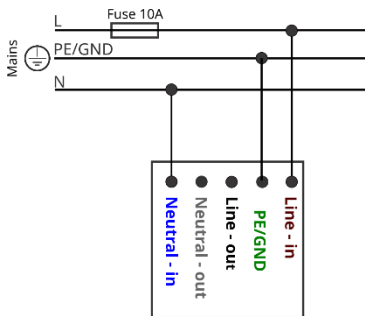

LED SPD T2&T3 10kVT  
T2 type connections  
when "end of life" is reached  
the protector is no more  
protects the line

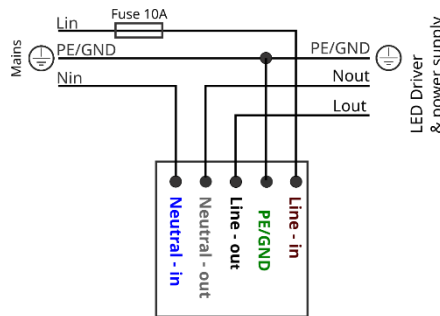

LED SPD T2&T3 10kVT  
T3 type connections  
when "end of life" is reached  
the protector and load are  
switched off from mains

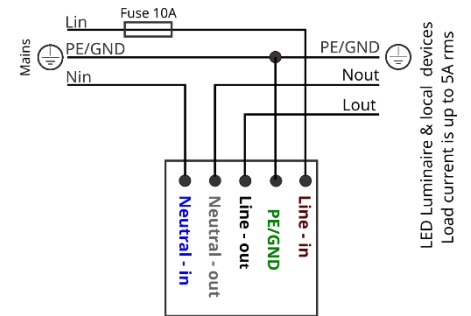

LED SPD T2&T3 10kVT  
T2 type connections  
when "end of life" is reached  
the protector and load are  
switched off from mains

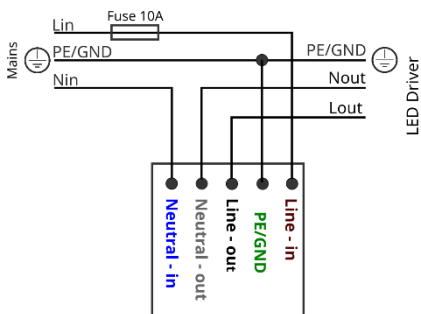

LED SPD 10kVL T3  
T3 type connections  
when "end of life" is reached  
the protector and load are  
switched off from mains

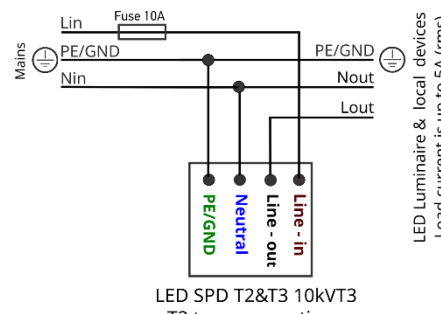

LED SPD T2&T3 10kVT2  
T2 type connection

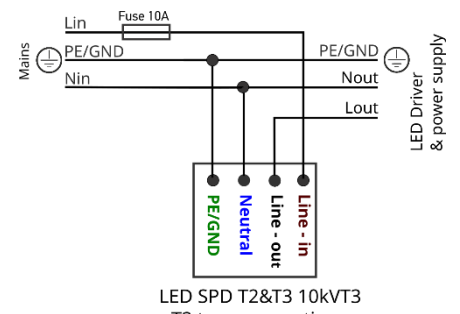

LED SPD T2&T3 10kVT3  
T3 type connection

**Product features**

The T2 and T3 type SPD have great surge energy absorbance. T2 type is an economic solution for local surge protection. T2 can be located inside the pole or inside the lighting fixture. The T3 type protector is generally installed in front of the terminal device (inside the lighting fixture) to be protected. The T2 and T3 type SPDs have fast response and durable components.

**Differences between the models**

a) The T2 type SPD will stop protecting the lighting fixture if its strike lives end.

The lighting fixture will continue to work, even though the T2 SPD has reached its maximum strikes capacity and is no longer functioning.

The T2 SPD can be positioned inside the lighting pole or inside the lighting fixture.

The advantage when T2 type SPD is used is easy monitoring and replacing – no need to use a platform.

No work-indication LED diode available on this model.

b) The T3 type SPD will stop powering the lighting fixture if its strike lives end.

The lighting fixture will stop working after the T3 SPD has reached its maximum strikes capacity and is no longer functioning. The SPD will be disconnected from mains supply and thus the protected device will stop working.

A qualified worker will have to replace the defective SPD with a new one, since it has to be placed inside the lighting fixture. In most cases it is needed using a platform.

The T3 type SPD has work-indication LED diode available.

When the strike lives of the SPD are over, the status LED indicator will stop working.

c) The models with "II" in the name do not have a ground wire and do not require safety and functionality grounding. They can be protect only safety Class II mains powered devices – power supplies and LED drivers.

d) The T2+T3 type SPD will stop powering the lighting fixture if its strike lives end.

The lighting fixture will stop working after the T2+T3 SPD has reached its maximum strikes capacity and is no longer functioning. The SPD will be disconnected from the mains supply and thus the protected device will stop working.

The advantage of this model is that it can be place inside the pole or inside the lighting fixture.

It can be easily monitored and replaced.

The T2+T3 type SPD has work-indication LED diode available.

When the strike lives of the SPD are over, the status LED indicator will stop working.

Coordinated work of T2 and T3 type SPD protectors is the better choice of usage.

**Compatibility between different models**

T3 "LED SPD 10kVL T3" with T2 "LED SPD 10kA T2";

T3 "LED SPD 10kVL T3" with T2 "LED SPD 20kA T2";

T3 "LED SPD 10kVL T3" with T2 connected "LED SPD T2&T3 10kVW";

T3 "LED SPD 10kVL T3" with T2 connected "LED SPD T2&T3 10kVT";

T3 connected "LED SPD T2&T3 10kVT" with T2 "LED SPD 10kA T2";

T3 connected "LED SPD T2&T3 10kVT" with T2 "LED SPD 20kA T2";

T3 connected "LED SPD T2&T3 10kVT" with T2 connected "LED SPD T2&T3 10kVW";

T3 connected "LED SPD T2&T3 10kVT" with T2 connected "LED SPD T2&T3 10kVT";

T3 connected "LED SPD T2&T3 10kVW" with T2 connected "LED SPD T2&T3 10kVW";

T3 connected "LED SPD T2&T3 10kVW" with T2 connected "LED SPD T2&T3 10kVT";

T3 connected "LED SPD T2&T3 10kVT3" with T2 "LED SPD 10kA T2";

T3 connected "LED SPD T2&T3 10kVT3" with T2 "LED SPD 20kA T2";

T3 connected "LED SPD T2&T3 10kVT3" with T2 connected "LED SPD T2&T3 10kVW";

T3 connected "LED SPD T2&T3 10kVT3" with T2 connected "LED SPD T2&T3 10kVT";

T3 "LED SPD 10kVIIL T3" with T2 "LED SPD 10kA T2";

T3 "LED SPD 10kVIIL T3" with T2 "LED SPD 20kA T2";

T3 "LED SPD 10kVIIL T3" with T2 connected "LED SPD T2&T3 10kVW";

T3 "LED SPD 10kVIIL T3" with T2 connected "LED SPD T2&T3 10kVT";

T3 connected "LED SPD T2&T3 10kVIIT" with T2 "LED SPD 10kA T2";

T3 connected "LED SPD T2&T3 10kVIIT" with T2 "LED SPD 20kA T2";

T3 connected "LED SPD T2&T3 10kVIIT" with T2 connected "LED SPD T2&T3 10kVW";

T3 connected "LED SPD T2&T3 10kVIIT" with T2 connected "LED SPD T2&T3 10kVT";